

Unique Features of ANVER Mechanical Vacuum Lifters

- Instant attach and release is provided via the hoist up and down movement. The attach and release alternates each lift cycle for fast, efficient handling. Mechanical vacuum lifters increase the speed and efficiency of the horizontal handling of sheet and plate, panels, and all types of nonporous materials.
- Simple to operate. One person can control the entire operation. No oil fumes or noise pollution.
- Easy to Maintain. Only the highest quality components and superior construction are used with few moving parts.
- Extremely Safe. Load cannot be released until it is set down on a surface.
- ANVER Mechanical Vacuum Lifters are suitable for 100% duty cycle 24 hour a day operation. They never overheat or burn out.
- Easy to Maintain and Keep Operating in Heavy Production Environments.
- ANVER Mechanical Vacuum Generators comply fully with and meet the standards of US ANSI ASME Standard B30.20 for below-the-hook lifting devices, as well as complying with OSHA and European requirements.



Standard on Each Generator

- Vacuum gauge
- Battery operated VLS, vacuum loss sensor and warning system
- Front, adjustable pivoting handle-bar
- Two shut-off valves with locking push-button, 3/8" NPT port (front/back)

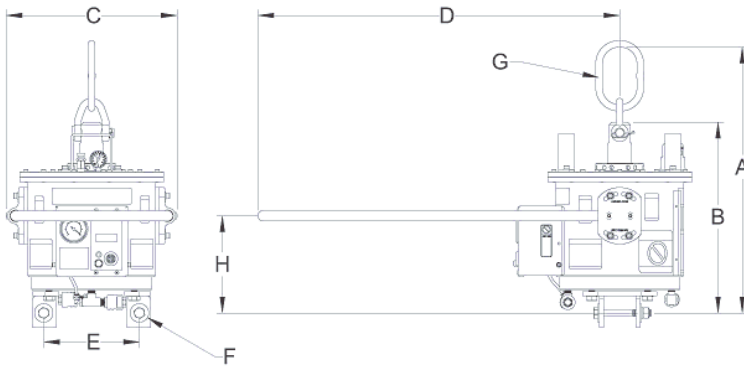

Generator Model	M150M	M150M-3X6	M250M	M250M-5X7	M250M-5X7H
Max. Rated Load lb (kg)	2200 (998)	2200 (998)	4400 (1996)	4400 (1996)	4400 (1996)
Fits Tube Size in (mm)	3×3 (76×76)	3×6 (76×152)	3×6 (76×152)	5×7 (127×178)	5×7 (127×178)
Unit Weight lb (kg)	168 (76)	170 (77)	302 (137)	305 (138)	320 (145)
A Max. Headroom in (mm)	30 (762)	31 (787)	32.25 (819)	32.75 (832)	32.75 (832)
B Min. Height in (mm)	17.1 (434)	18.6 (472)	20 (508)	20 (508)	20 (508)
C Handlebar Width in (mm)	16.1 (409)	16.1 (409)	22 (559)	22 (559)	22 (559)
D Handlebar Length in (mm)	34 (864)	34 (864)	34.75 (883)	34.75 (883)	34.75 (883)
E Hardware Centers in (mm)	9 (229)	9 (229)	12 (305)	12 (305)	12 (305)
F Mounting Hardware in (mm)	Provided	Provided	Provided	Provided	Provided
G Master Chain Link Dim. in (mm)	3.25×5.38 (83×137)	3.25×5.38 (83×137)	3.25×5.38 (83×137)	3.25×5.38 (83×137)	3.25×5.38 (83×137)
H Handlebar Height in (mm)	9.13 (232)	10.5 (267)	11.5 (292)	11.5 (292)	11.5 (292)