



ANVER'S Standard Vacuum Lifters offer efficient material handling solutions by promoting functionality, safety, and ergonomic operations for a wide variety of applications and materials. Standard lifting frames are built to order from stock using modular components, so there are hundreds of possible combinations depending on the vacuum generator, beam, crossarms, and vacuum cups selected.

Basic features on ANVER's Standard Horizontal Vacuum Lifters include: vacuum leakage sensor and warning system; attach/release slide valve with safety lock; and locking hand knobs on the adjustable vacuum pad, slide assemblies, and crossarms (when applicable).

ANVER Vacuum Lifters comply fully with and meet the standards of US ANSI ASME Standard B30.20 for below-the-hook lifting devices, as well as complying with OSHA and most European requirements.

The L100M4-61-2/44 and -86-2/44 four-pad lifting frames are ideal for handling carbon steel and stainless steel sheets and plates with a capacity up to 1000 lb (454 kg). The type of vacuum lifter – Mechanical, Air, or Electric – paired with the number of pads used will depend on your application needs. Foam pads are not available for mechanical vacuum generators.

*Lifting frame shown with vacuum generator and/or optional accessories, not included.

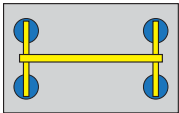

Crossarms and vacuum pads in maximum position to handle maximum plate size.

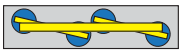

Crossarms can pivot to near parallel with spreader beam to handle narrow plates.

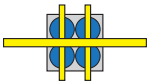

Vacuum pads and crossarms fully adjustable to handle short and narrow plates.

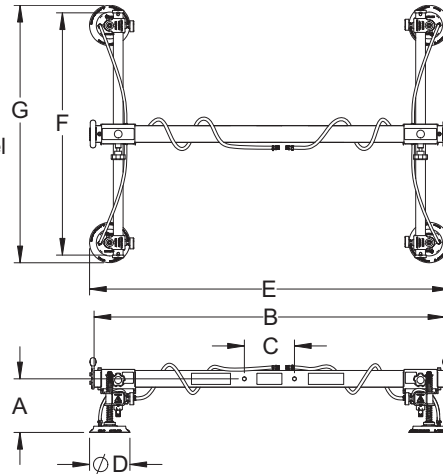

Lifting Frame Number	L100M4-61-2/44	L100M4-86-2/44
Rated Load Capacity [lbs (kg)]	1000 (454)	1000 (454)
Unit Weight [lbs (kg)]	120 (54)	135 (61)
A Lifting Frame Headroom [in. (mm)]	11.5 (292)	11.5 (292)
B Spreader Beam Length [in. (mm)]	63 (1600)	88 (2235)
C Hardware Mounting Centers [in. (mm)]	9 (229)	9 (229)
D Pad Diameter [in. (mm)]	9.25 (235)	9.25 (235)
E Pad Distances Maximum [in. (mm)]	64 (1626)	89 (2261)
E Pad Distances Minimum [in. (mm)]	34 (864)	34 (864)
F Crossarm Length [in. (mm)]	44 (1118)	44 (1118)
G Pad Distances Maximum [in. (mm)]	48 (1219)	48 (1219)
G Pad Distances Minimum [in. (mm)]	22 (559)	22 (559)
Maximum Sheet Size [ft (M)]	8 x 6 (2.4 x 1.8)	12 x 6 (3.7 x 1.8)
Seal Number	SSR-92	SSR-92

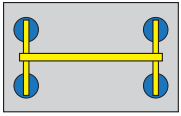

Crossarms and vacuum pads in maximum position to handle maximum plate size.

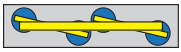

Crossarms can pivot to near parallel with spreader beam to handle narrow plates.

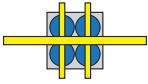

Vacuum pads and crossarms fully adjustable to handle short and narrow plates.

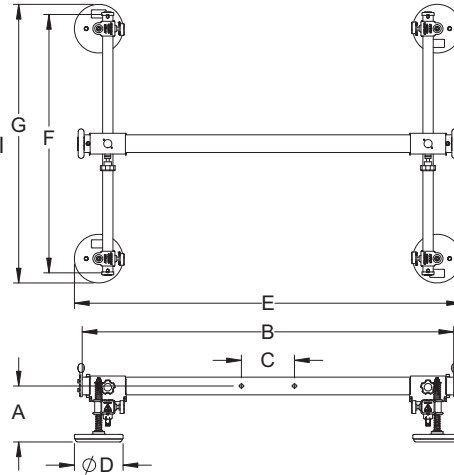

Lifting Frame Number	L100M4-61-2/44FP	L100M4-86-2/44FP
Rated Load Capacity [lbs (kg)]	1000 (454)	1000 (454)
Unit Weight [lbs (kg)]	155 (70)	170 (77)
A Lifting Frame Headroom [in. (mm)]	11.5 (292)	11.5 (292)
B Spreader Beam Length [in. (mm)]	63 (1600)	88 (2235)
C Hardware Mounting Centers [in. (mm)]	9 (229)	9 (229)
D Pad Diameter [in. (mm)]	12 (305)	12 (305)
E Pad Distances Maximum [in. (mm)]	69 (1753)	94 (2388)
E Pad Distances Minimum [in. (mm)]	36 (914)	36 (914)
F Crossarm Length [in. (mm)]	44 (1118)	44 (1118)
G Pad Distances Maximum [in. (mm)]	52 (1321)	52 (1321)
G Pad Distances Minimum [in. (mm)]	26 (660)	26 (660)
Maximum Sheet Size [ft (M)]	8 x 6 (2.4 x 1.8)	12 x 6 (3.7 x 1.8)
Seal Number	FR128	FR128