



ANVER'S Standard Vacuum Lifters offer efficient material handling solutions by promoting functionality, safety, and ergonomic operations for a wide variety of applications and materials. Standard lifting frames are built to order from stock using modular components, so there are hundreds of possible combinations depending on the vacuum generator, beam, crossarms, and vacuum cups selected.

Basic features on ANVER's Standard Horizontal Vacuum Lifters include: vacuum leakage sensor and warning system; attach/release slide valve with safety lock; and locking hand knobs on the adjustable vacuum pad, slide assemblies, and crossarms (when applicable).

ANVER Vacuum Lifters comply fully with and meet the standards of US ANSI ASME Standard B30.20 for below-the-hook lifting devices, as well as complying with OSHA and most European requirements.

The L200M8-231-4/44 eight-pad lifting frame is ideal for handling carbon steel and stainless steel sheets and plates with a maximum capacity of 2000 lb (900 kg). The type of vacuum lifter – Mechanical, Air, or Electric – paired with the number of pads used will depend on your application needs. Foam pads are not available for mechanical vacuum generators.

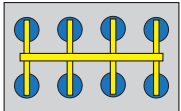

Crossarms and vacuum pads in maximum position to handle maximum plate size.



Crossarms can pivot to near parallel with spreader beam to handle narrow plates

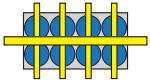

Vacuum pads and crossarms fully adjustable to handle short and narrow plates.

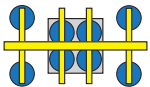

Inner crossarms and vacuum pads (1/2 capacity) for use with smaller plates. Outer pads provided with shut-off valves.

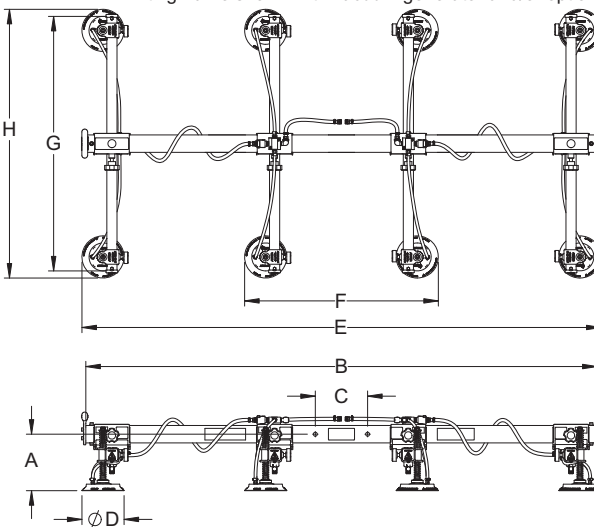

\*Lifting frame shown with vacuum generator and/or optional accessories, not included.

Lifting Frame Number	L200M8-86-4/44
Rated Load Capacity [lbs (kg)]	2000 (907)
Unit Weight [lbs (kg)]	250 (113)
A Lifting Frame Headroom [in. (mm)]	10 (254)
B Spreader Beam Length [in. (mm)]	88 (2235)
C Hardware Mounting Centers [in. (mm)]	9 (229)
D Pad Diameter [in. (mm)]	9.25 (235)
E Outer Pad Distances Maximum [in. (mm)]	93 (2362)
E Outer Pad Distances Minimum [in. (mm)]	53 (1346)
F Minimum Inner Pad Distance [in. (mm)]	34 (864)
G Crossarm Length [in. (mm)]	44 (1118)
H Outer Pad Distances Maximum [in. (mm)]	50 (1270)
H Outer Pad Distances Minimum [in. (mm)]	23 (584)
Maximum Sheet Size [ft (M)]	9 x 6 (2.7 x 1.8)
Seal Number	SSR-90

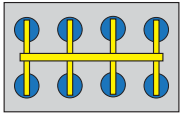

Crossarms and vacuum pads in maximum position to handle maximum plate size.



Crossarms can pivot to near parallel with spreader beam to handle narrow plates

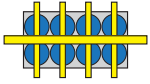

Vacuum pads and crossarms fully adjustable to handle short and narrow plates.

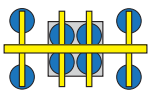

Inner crossarms and vacuum pads (1/2 capacity) for use with smaller plates. Outer pads provided with shut-off valves.

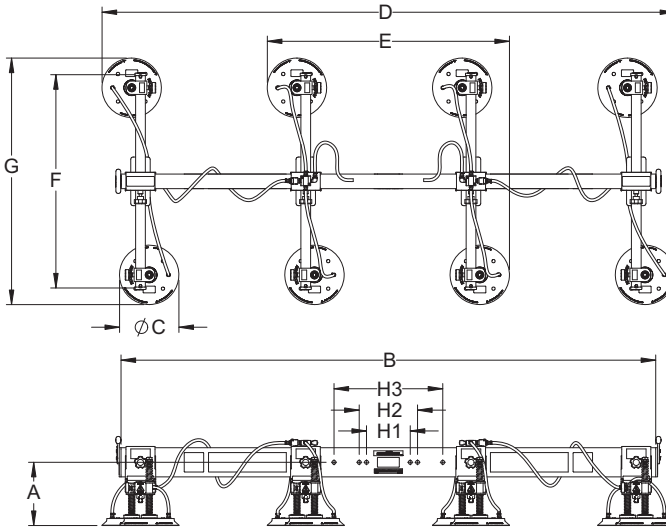

Lifting Frame Number	L200M8-150-4/44	L200M8-190-4/44	L200M8-231-4/44
Rated Load Capacity [lbs (kg)]	2000 (907)	2000 (907)	2000 (907)
Unit Weight [lbs (kg)]	330 (150)	370 (168)	580 (263)
A Lifting Frame Headroom [in. (mm)]	12 (305)	12 (305)	12 (305)
B Spreader Beam Length [in. (mm)]	150 (3810)	190 (4826)	231 (5867)
C Pad Diameter [in. (mm)]	9.25 (235)	9.25 (235)	9.25 (235)
D Outer Pad Distances Maximum [in. (mm)]	158 (4013)	198 (5029)	239 (6071)
D Outer Pad Distances Minimum [in. (mm)]	53 (1346)	53 (1346)	64 (1626)
E Minimum Inner Pad Distance [in. (mm)]	34 (864)	34 (864)	44 (1118)
F Crossarm Length [in. (mm)]	44 (1118)	44 (1118)	44 (1118)
G Outer Pad Distances Maximum [in. (mm)]	50 (1270)	50 (1270)	50 (1270)
G Outer Pad Distances Minimum [in. (mm)]	23 (584)	23 (584)	23 (584)
H1 Standard Hardware Mtg. Centers [in. (mm)]	9 (229)	9 (229)	9 (229)
H2 Inner Alternate Hardware Mtg. Centers [in. (mm)]	12 (305)	12 (305)	12 (305)
H3 Outer Alternate Hardware Mtg. Centers [in. (mm)]	22.38 (568)	22.38 (568)	22.38 (568)
Maximum Sheet Size [ft (M)]	16 x 8 (4.9 x 2.4)	20 x 8 (6.1 x 2.4)	25 x 8 (7.6 x 2.4)
Seal Number	SSR-90	SSR-90	SSR-90

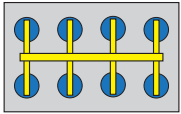

Crossarms and vacuum pads in maximum position to handle maximum plate size.



Crossarms can pivot to near parallel with spreader beam to handle narrow plates

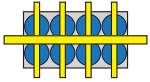

Vacuum pads and crossarms fully adjustable to handle short and narrow plates.

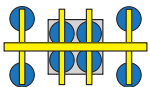

Inner crossarms and vacuum pads (1/2 capacity) for use with smaller plates. Outer pads provided with shut-off valves.

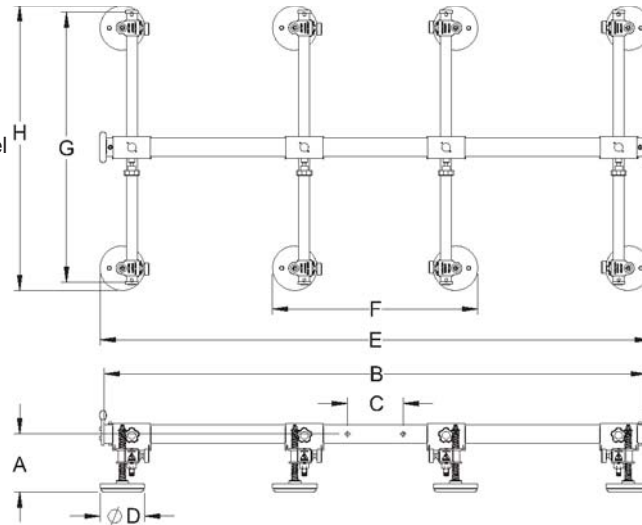

Lifting Frame Number	L200M8-86-4/44FP	L200M8-110-4/44FP
Rated Load Capacity [lbs (kg)]	2000 (907)	2000 (907)
Unit Weight [lbs (kg)]	315 (143)	340 (154)
A Lifting Frame Headroom [in. (mm)]	11.5 (292)	11.5 (292)
B Spreader Beam Length [in. (mm)]	88 (2235)	112 (2845)
C Pad Diameter [in. (mm)]	12 (305)	12 (305)
D Outer Pad Distances Maximum [in. (mm)]	94 (2388)	118 (2997)
D Outer Pad Distances Minimum [in. (mm)]	60 (1524)	60 (1524)
E Minimum Inner Pad Dimensions [in. (mm)]	36 (914)	36 (914)
F Crossarm Length [in. (mm)]	44 (1118)	44 (1118)
G Outer Pad Distances Maximum [in. (mm)]	52 (1321)	52 (1321)
G Outer Pad Distances Minimum [in. (mm)]	26 (660)	26 (660)
H Hardware Mounting Centers [in. (mm)]	9 (229)	9 (229)
Maximum Sheet Size [ft (M)]	9 x 6 (2.7 x 1.8)	12 x 6 (3.7 x 1.8)
Seal Number	FR128	FR128