

### Bottom Swivel Assembly Features:

- The 360° bottom swivel assembly, made of 304 stainless steel, allows full rotation of the load under the vacuumtube lifter control head. This allows the attached load to be precisely spun into position while keeping the control head in front of the operator.
- Allows for easier and more precise positioning of loads. Commonly used when unloading pallet loads of boxes to a skid with different orientations.
- Designed to offer easy rotation with just enough drag so that the load does not just keep spinning.

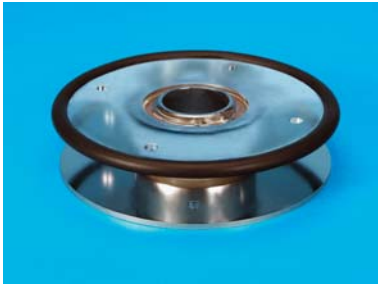

Part Number	Use With Series	A [in (mm)]	B [in (mm)]	No. of Mtg. Holes
VT-SW-M	Mini	3.15 (80)	1.8 (45)	2
VT-SW-M-LP	Mini	3.15 (80)	1.8 (45)	2
VT-SW-S	Standard	4.72 (120)	1.8 (45)	4
VT-SW-S-LP	Standard	4.72 (120)	1.8 (45)	4

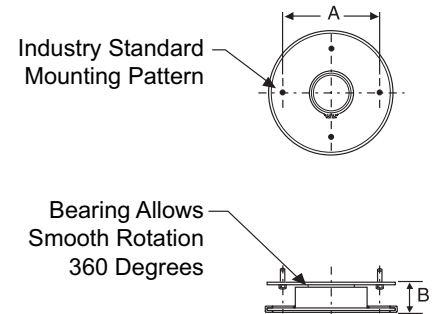

### Universal Swivel Features:

- ANVER's Stainless Steel Universal Swivels are used to save wear and tear to the vacuum lifting tubes while handling somewhat unbalanced loads.
- The universal swivel ensures that the load's weight hangs directly under the center of the vacuum lift tube, extending the lift tube life.
- Quality construction using heavy gauge stainless steel with all wear points using nylon bearing sleeves. The swivel comes with four mounting holes of which two will fit most other vacuum tube lifters on the market.



Part Number	Use With Series	A [in. (mm)]	B [in. (mm)]
VT-UAS-M	Mini	3.15 (80)	4.75 (121)
VT-UAS-S	Standard	4.72 (120)	5.75 (146)

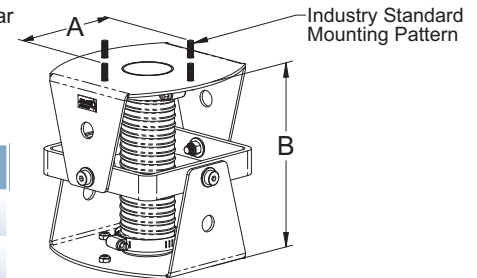

### 90° Tilter Adapter – Below the Head Type

90° Gravity Tilters are useful when your application calls for repeatedly moving the load from vertical to horizontal. They are used to automatically return the vacuum pads to a vertical position. They are not to be used to tilt the load. These tilters are designed to use gravity to tilt the load. An indexing plunger holds the pad in place for horizontal attachment. A flexible vacuum hose and two seal gaskets provide an airtight connection between the vacuum system and pad. The industry standard mounting hole pattern allows you to use the adapter on any vacuum pad.

**Note:** If single pad hits back of VT handlebar, quick release extension may be required.

\* Gas Springs are available in various capacities. Consult factory to determine the best choice for your application.

\*\* Horizontal Handlebar must be 12" or longer.

\*\*\* Horizontal Handlebar must be 18" or longer.



Model No.	Use With Series	A [in (mm)]	B [in (mm)]	Optional Handle Part No.	Optional Lock Part No.
VT-TILT-M	Mini	3.15 (80)	4.75 (120)	VT-TILT-M-H	N/A
VT-TILT-M-1G*	Mini	3.15 (80)	6.25 (159)**	N/A	N/A
VT-TILT-S	Standard	4.72 (120)	7.44 (189)	VT-TILT-S-H	N/A
VT-TILT-S-1G*	Standard	4.72 (120)	7.91 (201)***	N/A	VT-TILT-S-1GL

