

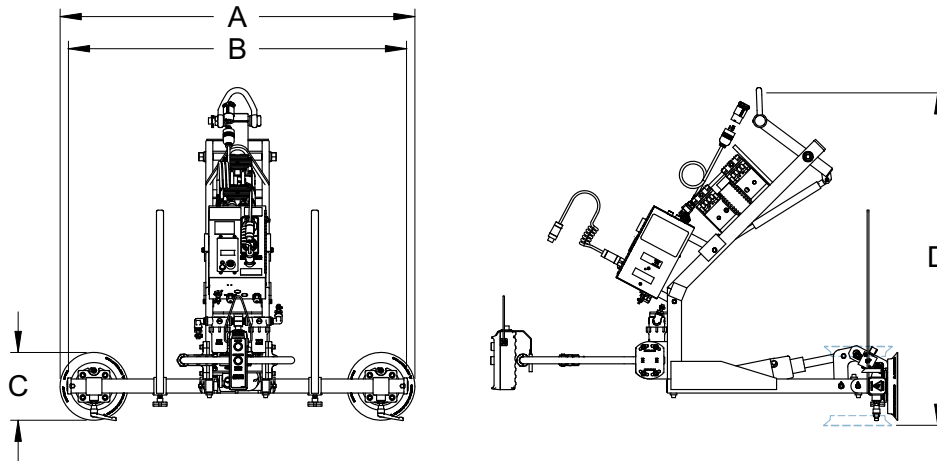

ANVER's Upender 180° Flipper is a C-frame style lifter that lets one person lift sheets and panels, invert them, inspect the other side, and then place them in jigs for assembly or secondary operations. Featuring two double vacuum suction pads to assure even loading and stress-free handling.

Features:

- EP1001 vacuum generator with vacuum gauge and master on/off switch.
- Tilt control pendant with 10 ft. coil cord.
- Power required: 115V/60hz/1ph/5A. 18 amp service required.
- Vacuum pump/motor 4.3 SCFM (121.8 l/min), 1/2 HP; equipped with thermal sensor to prevent overheating and 100% duty cycle.
- VLS, 9V battery powered vacuum leakage sensor and warning system.
- Resettable circuit breaker for vacuum pump.
- Electrical cord with twist lock, male and female receptacles.
- Check valve to halt loss of vacuum in case of electrical power failure.
- Load placement guides.
- Self-balancing lifting shackle



Model No.	EF25M2-36C180	EF25M2-48C180	EF25M2-60C180	EF25M2-72C180	EF25M2-84C180
Rated Load Capacity [lbs (kg.)]	250 (113)	250 (113)	250 (113)	250 (113)	250 (113)
Unit Weight [lbs (kg.)]	178 (81)	183 (83)	188 (86)	193 (88)	198 (90)
A Pad Distances Max. [in. (mm)]	43 (1092)	55 (1397)	67 (1701)	79 (2006)	91 (2311)
A Pad Distances Min. [in. (mm)]	28 (712)	28 (712)	28 (712)	28 (712)	28 (712)
B Beam Length [in. (mm)]	36 (914)	48 (1219)	60 (1524)	72 (1829)	84 (2134)
C Pad Dimension [in. (mm)]	9.25 (235)	9.25 (235)	9.25 (235)	9.25 (235)	9.25 (235)
D Maximum Lifter Headroom [in. (mm)]	47 (1194)	47 (1194)	47 (1194)	47 (1194)	47 (1194)
Maximum Load Length x Width [ft. (M)]	5 x 4 (1.5 x 1.2)	6 x 4 (1.8 x 1.2)	8 x 4 (2.4 x 1.2)	10 x 4 (3.0 x 1.2)	12 x 4 (13.7 x 1.2)
Maximum Load Thickness [in. (mm)]	1 (25.4)	1 (25.4)	1 (25.4)	1 (25.4)	1 (25.4)
Pad Number	VP90	VP90	VP90	VP90	VP90