

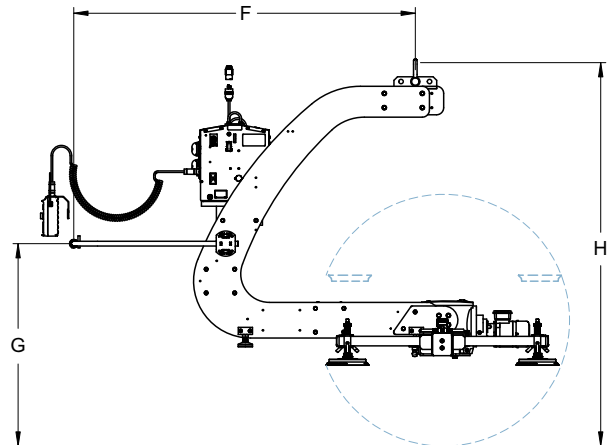

ANVER's Upender 180° Flipper is a C-frame style lifter that lets one person lift sheets and panels, invert them, inspect the other side, and then place them in jigs for assembly or secondary operations. Featuring four vacuum suction pads to assure even loading and stress-free handling.

Features:

- VPE1-GEN2 vacuum generator with vacuum control module, vacuum gauges and vacuum leakage sensor and warning system.
- Attach/Release Pendant with Tilt Controls & Safety Lock-Out.
- Power required: 120V/1PH/60HZ, 20 Amps.
- Vacuum pump/motor 4.3 SCFM (121.8 l/min), 1/2 HP; equipped with thermal sensor to prevent overheating and 100% duty cycle.
- Resettable circuit breaker for vacuum pump.
- Electrical cord with twist lock, male and female receptacles.
- Check valve to halt loss of vacuum in case of electrical power failure.
- Heavy duty helical worm gearbox and motor.
- Three position lifting shackle.

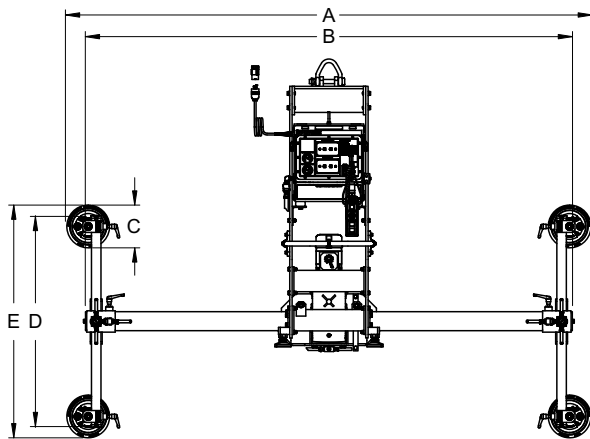

Model No.	EF50M4-86C180-2/44
Rated Load Capacity [lbs (kg.)]	500 (227)
Unit Weight [lbs (kg.)]	825 (374)
A Pad Distances Max. [in. (mm)]	94 (2387)
A Pad Distances Min. [in. (mm)]	44 (1123)
B Beam Length [in. (mm)]	86 (2184)
C Pad Dimension [in. (mm)]	9.25 (235)
D Crossarm Length [in. (mm)]	44 (1123)
E Pad Distances Along Crossarm Max. [in. (mm)]	49 (1244)
E Pad Distances Along Crossarm Min. [in. (mm)]	24 (610)
F Handlebar Length [in. (mm)]	72 (1829)
G Handlebar Height Max. [in. (mm)]	43 (1092)
G Handlebar Height Min. [in. (mm)]	22 (559)
H Maximum Lifter Headroom [in. (mm)]	81 (2058)
Maximum Load Length x Width [ft. (M)]	12 x 6 (3.6 x 1.8)
Maximum Load Thickness [in. (mm)]	2.25 (57)
Pad Number	VP90