

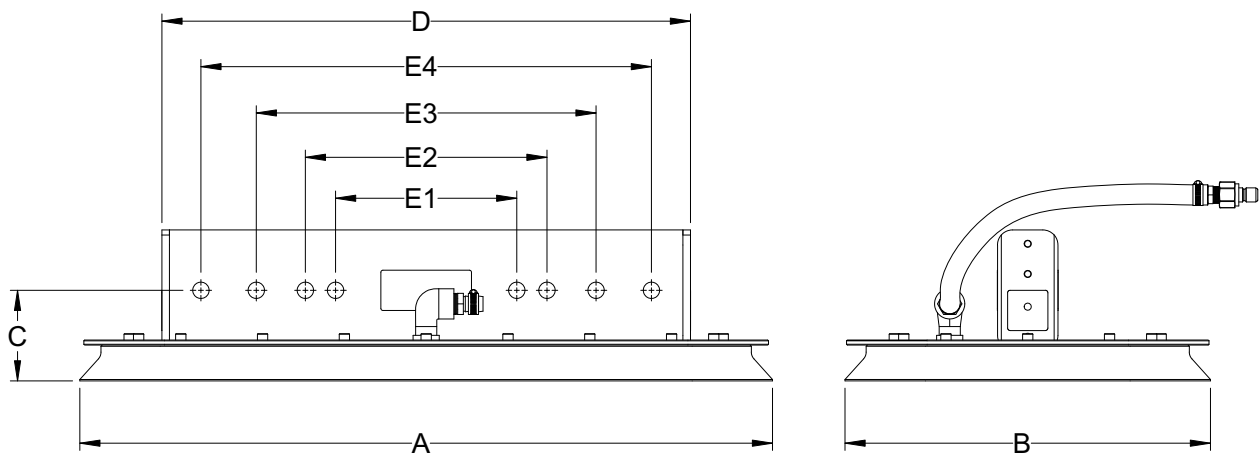

ANVER Large Capacity Vacuum Pad Attachments are ideal for lifting heavy, compact loads in situations where the available load surface precludes the use of lifters with multiple smaller pads. These large capacity pads are made by ANVER to be sturdy and safe when handling heavy loads.

Features:

- Sturdy Heavy Steel Steel Construction, Top Steel Clamp extends to protect the sealing ring
- Replacement Bolt-On Vacuum Seal can be changed by hand with an Allen wrench
- High Lifting Capacity and welded construction
- Rubber scuff pad on the under side, large vacuum port for quick response times
- Available with either Nitrile or Silicone Rubber Seals for high heat applications



| Pad Attachment Number | PA2129-S-36 | PA1834-S-36 |
|---|--------------|-------------|
| Pad Attachment Number | PA2129M-S-36 | PA1834-S-36 |
| Rated Load Capacity with M250M lb. (kg) | 2800 (1270) | 3000 (1361) |
| Rated Load Capacity with Powered Generator lb. (kg) | 2800 (1270) | 3200 (1452) |
| Unit Weight lb. (kg) | 115 (52) | 140 (64) |
| A Pad Length in. (mm) | 29.75 (756) | 35.13 (892) |
| B Pad Width in. (mm) | 21 (533) | 19.13 (486) |
| C Pad Attachment Headroom in. (mm) | 4.5 (114) | 4.5 (114) |
| D Beam Length in. (mm) | 20.8 (528) | 26.3 (668) |
| E1 Hardware Mounting Centers in. (mm) | 9 (229) | 9 (229) |
| E2 Alternate Hardware Mounting Centers in. (mm) | 12 (305) | 12 (305) |
| E3 Alternate Hardware Mounting Centers in. (mm) | 16.88 (429) | 16.88 (429) |
| E4 Alternate Hardware Mounting Centers in. (mm) | N/A | 22.38 (568) |

*The cup capacities shown above are based on 24"Hg at sea level with a safety factor of two (2) in the horizontal (flat) position. Rated Load Capacities are estimated; actual capacity will vary based on the load surface and the level of vacuum.

When used with M250M ANVER Mechanical Vacuum Generator, the PA1834-S-36 vacuum pad is derated to 3000 lb. (1361 kg) – Contact factory for more information. For Single/Dual Pad Attachment used under ANVER Vacuum Generators – Contact factory for more information.

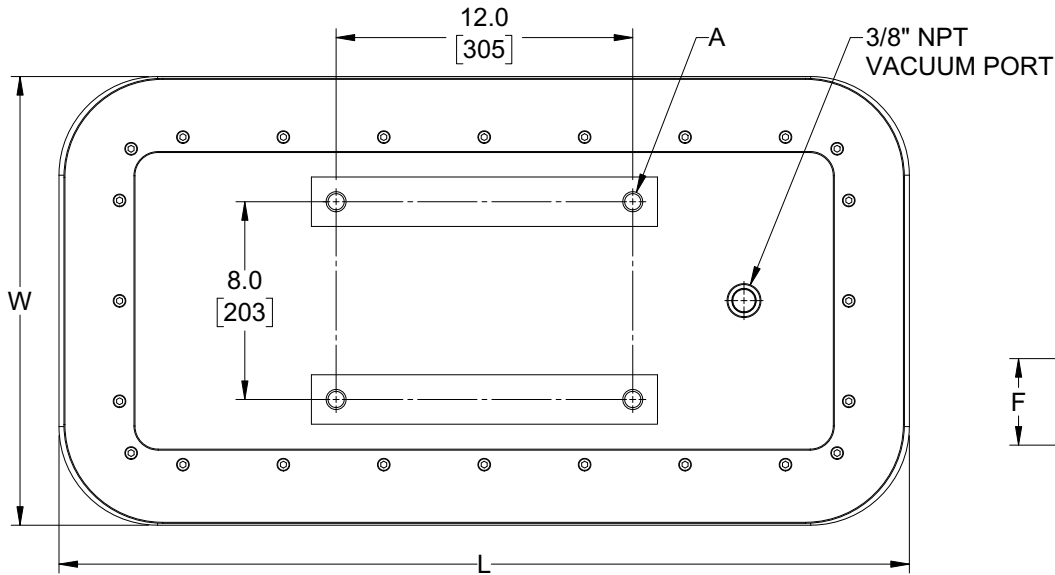

| Part Number | VP2129Q | VP2129Q-M | 76201157 | VP1834Q | VP1834Q-M | 76200887 | 76201158 |
|-------------------------|-------------|-------------|-------------|-------------|-------------|-------------|-------------|
| A Mounting Holes | 3/4-10 UNC | M20x2.5 | M24x3.0 | 3/4-10 UNC | M20x2.5 | 1-8 UNC | M24x3.0 |
| F Height in. (mm) | 0.68 (17) | 0.68 (17) | 0.68 (17) | 0.88 (22) | 0.88 (22) | 0.88 (22) | 0.88 (22) |
| Replacement Seal Number | SR-2129M | SR-2129M | SR-2129M | SR-1834-DP | SR-1834-DP | SR-1834-DP | SR-1834-DP |
| W in. (mm) | 21.00 (533) | 21.00 (533) | 21.00 (533) | 19.13 (486) | 19.13 (486) | 19.13 (486) | 19.13 (486) |
| L in. (mm) | 29.75 (756) | 29.75 (756) | 29.75 (756) | 35.13 (892) | 35.13 (892) | 35.13 (892) | 35.13 (892) |
| Weight lb. (kg) | 115 (52) | 115 (52) | 115 (52) | 140 (64) | 140 (64) | 140 (64) | 140 (64) |
| Rated Load* lb. (kg) | 2800 (1270) | 2800 (1270) | 2800 (1270) | 3200 (1451) | 3200 (1451) | 3200 (1451) | 3200 (1451) |